



A MOTORCYCLE MCOMPONENTS

www.mcomp.co.za

South African Importer Distributor

KEYSTER

Made in Japan

Tel: 073 750 9697 Fax: 086 684 1544 e-mail: mcomp@mweb.co.za
PO Box 59 Pennington 4184

Part No / Hole Space

P1 / 35mm



Make Model

GAS GAS	All listed models
Honda	CR125 & CR250 (84-85), CR500 (85-86)
KTM	Most models - check KTM page for full listing.
Suzuki	RM125, RM250, RMZ250F

P2 / 30mm



Honda	CR125 (90-96), CR250 (89-96)
Yamaha	RD250, RD350, YFZ350 Banshee

P3 / 33mm



KTM	65SX, 85SX
Yamaha	YZ125, WR250F (01-02), YZ250 (76-90 & 96 on), YZ250F, WR400, YZF400, WR426, YZF426

P4 / 36mm



Honda	XR250R, XR400R, XR650R
--------------	------------------------

P5 / 35mm



Yamaha	Yamaha WR250F (03 on), WR450F (03 on)
---------------	---------------------------------------

P6 / 36mm



Honda	XL250R, XL250FRVC, XR250
Suzuki	RM100, DR350, DR400Z, DR600S, DR650R/RE/RS/S, DR750/S, DR800S
Yamaha	YFM350 Warrior

P7 / 30mm



Honda	CR125 (97 on), CR250 (97 on), CR500 (87 on)
Kawasaki	KX80 (89 on), KX85 (2002), KX100 (89 on), KX125, KX250, KMX250

P8 / 30mm



Ducatti	Twins (2 per bike)
----------------	--------------------

P11 / 34mm



Universal

P12 / -



Triumph | PVL & Gill ignition systems

P13 / 38mm



Honda | Honda CRF250, CRF450

P14 / -



Yamaha | Yamaha WR250 (90-95), YZ250 (90-95)

P20 / 34mm



Honda | CRF50, XR50, XR80, CRF100, XR100, CRF150

P21 / 34mm



Universal |

P22 / 33mm



Universal |

P30 / -



Yamaha | Yamaha: YZ490, YZ465

P31 / -



Kawasaki | Kawasaki KDX200 (89 on), KX500 (84 -89)

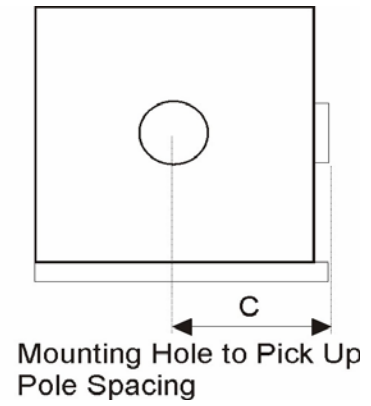
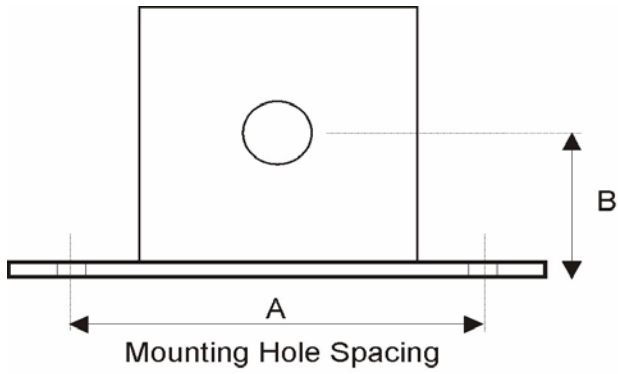

Pulse Coil	Dim A	Dim B	Dim C	Resistance Ω	Note
P1	35	13	6	100	
P2	30	13	3	128	
P3	33	6	9	250	
P4	36	14	10	220	
P5	35	8	7	280	
P6	35	14	5	280	Was P10
P7	30	14	3	228	
P11	34	14	4	230	
P13	38	7	9	250	
P20	34	15	4	150	
P21	36	15	6	120	
P22	33	6	12	440	

All dimensions in mm